

GT EzWaiter™

Benefits the whole family!

Residential Dumbwaiter

BEST WARRANTY ON THE MARKET

GT
Silver
1-Year
Warranty*



Global Tardif is proud to introduce the **GT EzWaiter™**, the most convenient residential dumbwaiter in the residential market!

The **GT EzWaiter™** is specially designed to improve the quality of life at home. The **GT EZWaiter™** quickly carries groceries, laundry and firewood effortlessly or any other heavy loads you wish to eliminate from your daily routine. Imagine, the simple touch of a button, the **GT EzWaiter™** moves loads from 2, 3, or 4 floors. Backaches and irritants due to stair climbing will no longer exist.

Easy to install and designed to take up very little room, it can be installed in any type of residence, new or existing, even in a typical closet space for example!

Safe for kids, the GT EzWaiter™ is very easy to use and will add "value" to your home.

- Essential for everyone
- Affordable
- Safe
- Practical
- Effortless
- EZ to Install
- EZ to Use
- Simple & Reliable
- Relay Logic GT-EZW™ Control
- Corrosion Protection
- Galvanized Steel Construction
- 3.5 ft² with 9 ft³ Volume
- CSA Approved Components
- Visit Our Website at :

GT Accessibility.com

since 1984



Elevator Manufacturing Group



Standard Features

- 100 lbs. (45 kg) Capacity
- 35 fpm (0,175 m/s) Speed
- 1/2 HP Motor
- 120V / 1 PH /60 HZ - 15 amps
- Roped 1:1 Basement Drum Cable System
- Slack / Broken Cable Safety Device
- Call Operation
- Quiet Machine
- Illuminated "Car Here" Indicator
- Counter-loading or Floor Loading
- Standard Cab Size of 22.5" W x 22.5" D x 30" H (570 x 570 x 760)
- Front or Front & Rear Openings
- Overload Protection

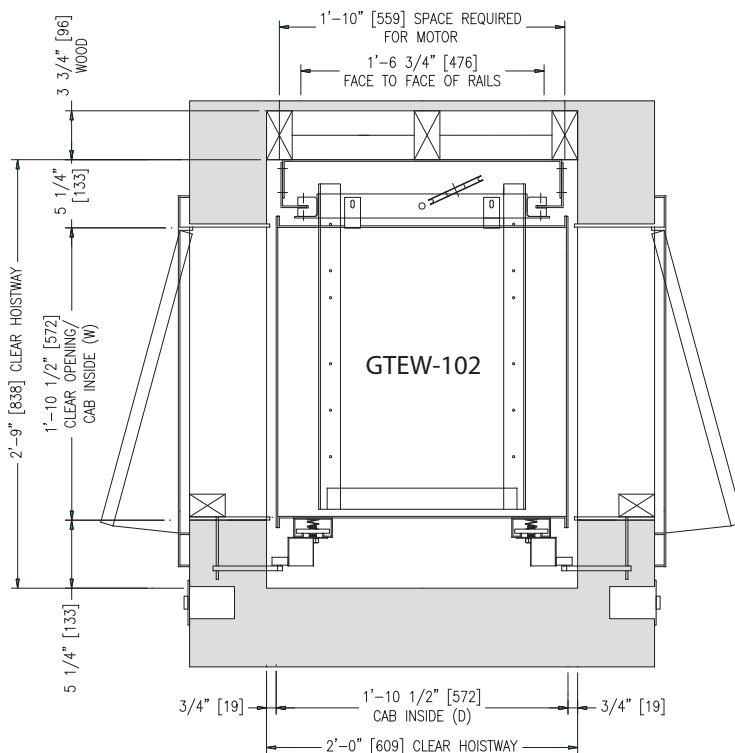
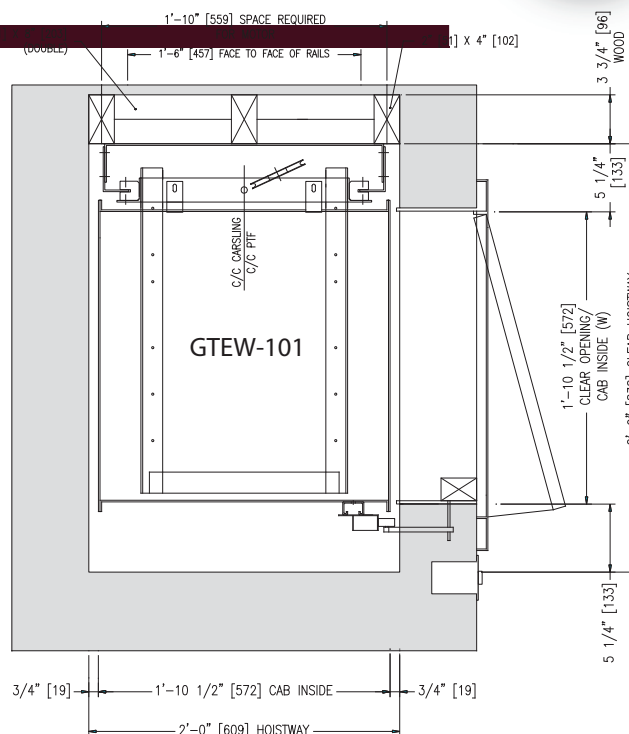
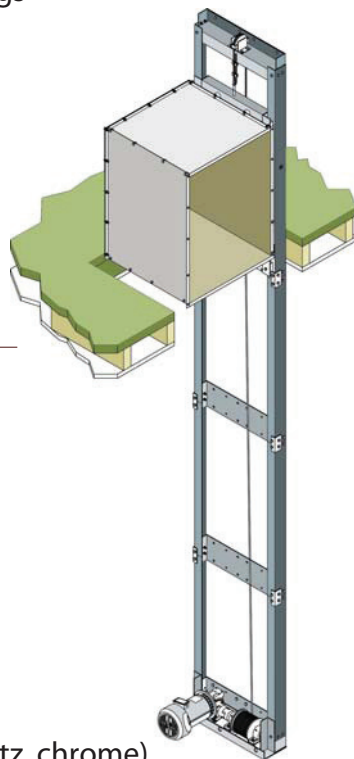

Options

- Additional Stops (5 - 6 - 7)
- Additional Travel
- Custom Dimensions
- Custom Finishes
- Front & Side Openings
- GT Landing Swing Door
- Call and Send Operation
- Luxury Stations (Bronze, muntz, chrome)
- CAB Shelves
- CAB Light
- CAB Door

For more information and detailed drawings
visit our web site at
www.gtaccessibility.com

Your Authorized Dealer is:



*The GLOBAL-TARDIF Limited Warranty covers replacement of any defective parts for a period of one (1) year. Labour cost not included. GLOBAL-TARDIF reserves the rights to discontinue models or options at any time or change the specifications, materials, equipment or pricing without notice and without incurring obligation. U.S. and foreign patents pending. 2004 GLOBAL-TARDIF Elevator Manufacturing Group Inc.