

GT 100™

For Heavy Duty Application

Commercial Wheelchair Lift

EXPRESS

GT
Silver
1-Year
Warranty*



Since 1984, Global-Tardif has earned a top reputation as a manufacturer of field proven, innovative products for the elevator industry. The company has grown to become one of the largest independent manufacturers of elevators in North America.

Global Tardif is proud to introduce its traditional hydraulic **GT 100™** to complement its complete line of pre-engineered wheelchair lift solutions for commercial applications.

The **GT 100™** is specially engineered and designed to facilitate access for people with physical disabilities up to 6 floors. The **GT 100™** is the right choice for building owners and architects looking for an architectural, Heavy Duty vertical wheelchair platform lift.

- Stock, delivery 2-3 weeks
- Approval drawings, 2-3 days
- 1000 lbs Capacity
- Easy to Install (one person required)

- Outstanding Quality Performance
- Full Cab - 6'-8" (2032 mm) Height
- Heavy Duty Steel Construction
- Proven Reliability
- All Safety Features Included
- Easy to Use
- Low Maintenance
- CSA Approved Components
- Visit Our Website at :

GT Accessibility.com

since 1984

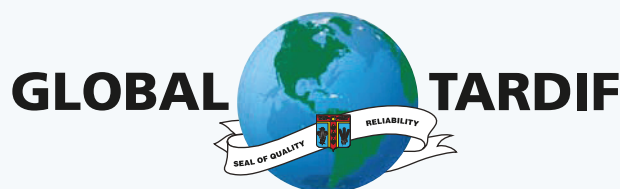

Elevator Manufacturing Group



Standard Features

- 1000 Lbs (454 kg) Capacity
- 1:2 Cable Hydraulic Drive System
- 30 FPM (0.15 m/sec)
- 3 HP
- 220V/1ph/ 60Hz
- **GT-EZ100™** Control - Simple & Reliable Relay Logic
- Submersible Motor with Submersible Pump Unit **GT-100SBPower™**
- 10" (254 mm) Pit Depth Only
- 96" (2438 mm) Overhead
- Constant Pressure Operation
- Emergency UPS Lowering Device
- Emergency Manual Lowering Valve
- Two Way Levelling
- Slack / Broken Cable Safety Device
- Emergency Stop Button with Alarm
- Automatic Emergency Lighting
- Down Speed Flow Control
- Low Pressure Switch Safety Device
- Emergency Pit Switch
- "In Use" Indicator
- Phone Cabinet

EXPRESS

Options

- Automatic GT Swingdoors™
- Retiring Cam
- Custom Plastic Laminate
- Rubber Mat Flooring
- Hands Free Phone

Opening configurations

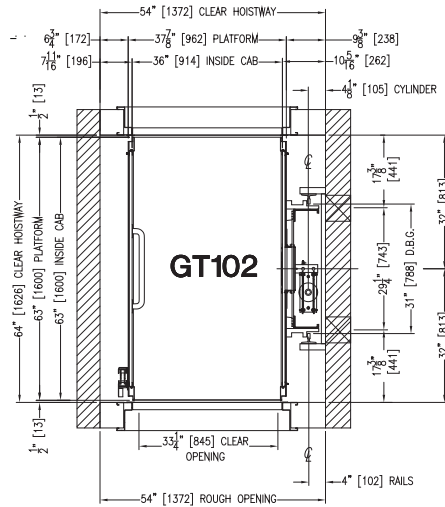
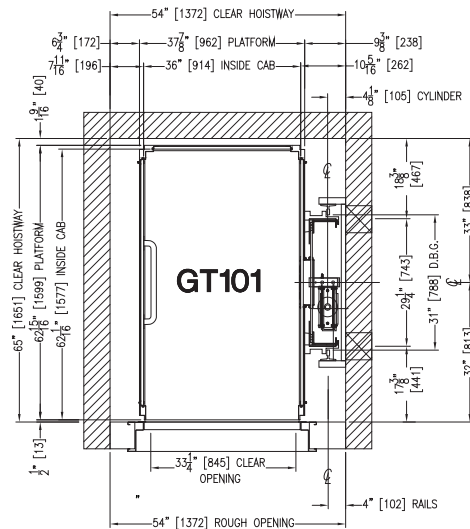

Standard Cab Features

- 6'-8" (2032 mm) Cab Height
- Two (2) Standard Cab Wall Color Selection
- Stainless Steel #4 modular CAB shell wall reveals and bases
- Stainless Steel Satin Car Operating Panel
- Ceiling: in Melamine Panel with 2 recessed Pot Lights
- Plywood Flooring with Recess to allow Floor Finish by Others
- Stainless Steel Satin Handrail

Standard GT-Swing™ Doors Features

- 1 ½ Hr UL / ULC Fire Rated Entrance Assembly
- Swing Clear Non Exposed Stainless Steel Hinges
- Hollow Metal Door Panels with Wired Mesh Clear Vision Glass Insert
- Zinc Coated
- Anti Skid Sill Plate
- GAL Door Interlock - Type "N"
- Integrated Hall Station
- Hydraulic Door Closer

Your Authorized Dealer is:

For more information and detailed drawings

visit our web site at

www.gtaccessibility.com



* The GLOBAL-TARDIF Limited Warranty covers replacement of any defective parts for a period of one (1) years. Labour cost not included. GLOBAL-TARDIF reserves the rights to discontinue models or options at any time or change the specifications, materials, equipment or pricing without notice and without incurring obligation. U.S. and foreign patents pending. 2004 GLOBAL-TARDIF Elevator Manufacturing Group Inc.