

ELEVATION

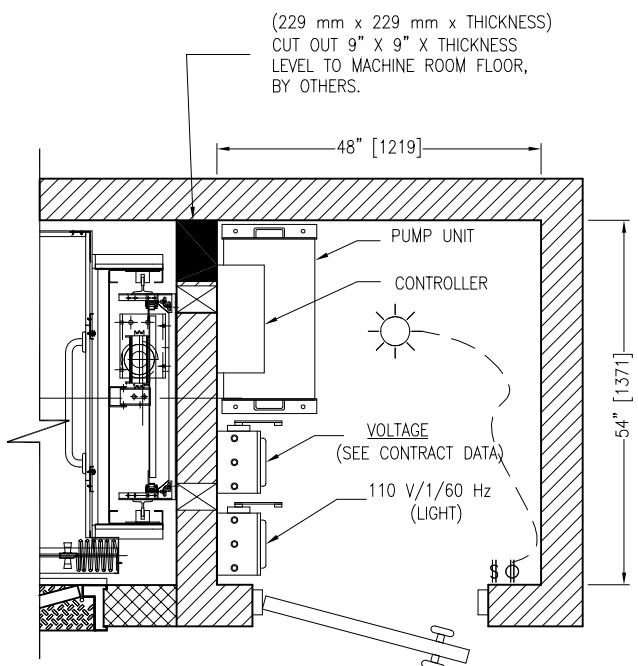

TYPICAL MACHINE ROOM PLAN

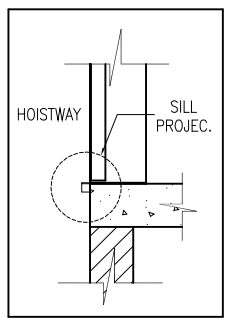

SILL DETAIL

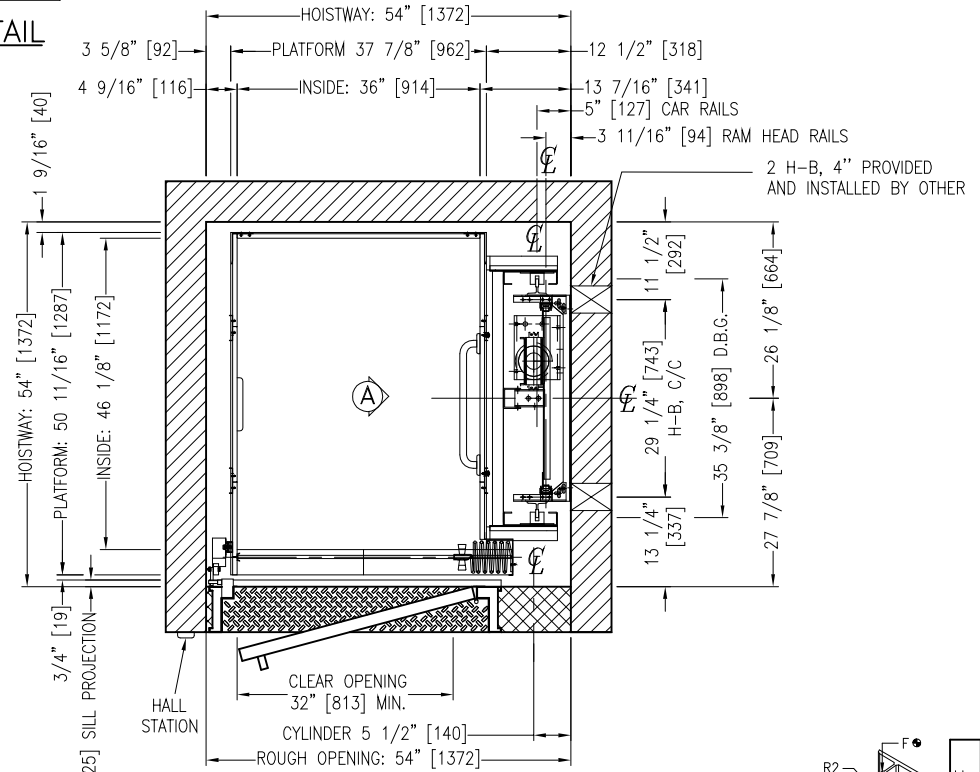

PLAN OF HATCH

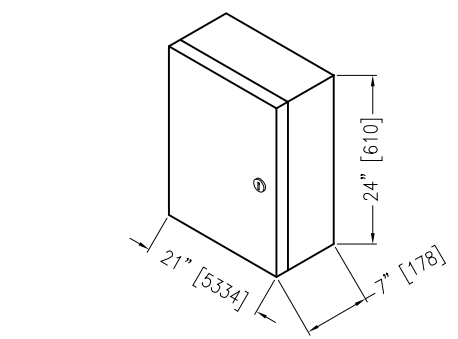

CONTROLLER

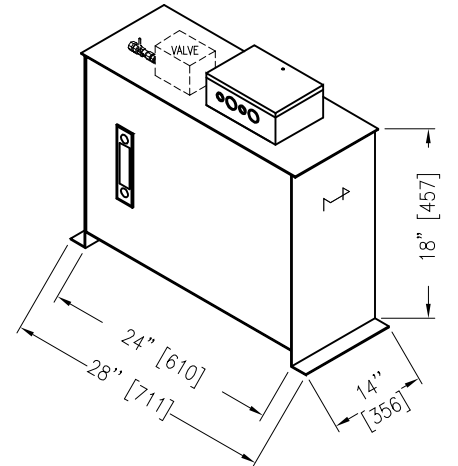

POWER UNIT

NOTE: ALL DIMENSIONS BETWEEN BRACKETS ARE IN MILLIMETERS

THIS INSTALLATION IS DRAWN IN ACCORDANCE WITH THE CAN-CSA-B44-04 SECTION 5.3

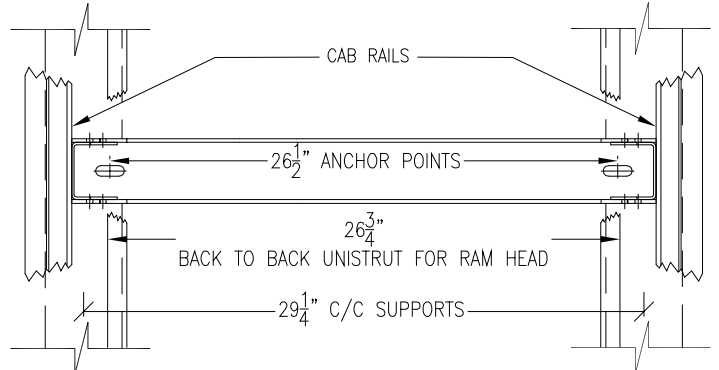

RAIL BRACKET DETAIL

ELEVATOR QTY	2
ELEVATOR TYPE	ROPED-HYDRAULIC
CAPACITY	750 LBS [340 Kg]
CLASSIFICATION	RESIDENTIAL
PERSON/S	2
NEMA CONDITION	NEMA 1
ELEVATOR SPEED	___FT/MIN [___M/S]
HOISTWAY DOOR	MANUAL
LIMITS SWITCH	OMRON : DAN
CONTROLLER	JRT
STOPS / FRONT OPENINGS	/
SEISMIC ZONE	ZONE 0
LEVELING TYPE	AUTOMATIC
OPERATION	SINGLE AUTOMATIC
VOLTAGE/PHASE/CYCLE	/ /
MOTOR	___HP @ ___RPM
STARTING AMP.	AMP.
FULL LOAD AMP.	AMP.
PUMP	
VALVE	___GAL US ___L
REQUIRED OIL, GALS	___GAL US ___L
OIL LINE PIPE	#1/2 100R2
OIL FLOW	GPM
WORKING PRESSURE	PSI
MAXIMUM PRESSURE	PSI
CYLINDER Ø / WALL	4 1/2 Ø (114MM) / WALL 1/4" (6.35MM)
PISTON Ø / WALL	2 3/4 Ø (70MM) / WALL 1/4" (6.35MM)
CAR RAIL	5.78 LBS/FT / 8.6 KG/M
RAM HEAD RAIL	UNISTRUT 1" X 1-5/8"
TYPE OF GUIDE	NYLON
CAB STEADIER	FIXE
RAM HEAD PULLEY	10 3/4 Ø
CAR SAFETY TYPE	SAFGT01
CAR RAIL : MAXIMUM SPACING	6" 0"
CAR BUFFER	RUBBER 1/2"
HOIST ROPE QTY/SIZE/LENGTH	2 CABLES 3/8Ø CLASS 7 X 19 AIRCRAFT
CABLE BREAKING STRENGTH	14440 LBS (6538 KG) / CABLE
SECURITY FACTOR	21.7
PLATFORM TYPE	2 PLYWOOD
SILL DEPRESSION	NONE OR 3/4"
SURFACE	12 FT / 1.12 M
TOE GUARD	3"
TYPE OF SILL	□ ALUMINUM □ OTHERS: _____
WEIGHT CAB	582 LBS (264 KG)
CARSLING	188 LBS (85 KG)
FLOORING WEIGHT (MAXIMUM)	35 LBS (16 KG)
PLATFORM (W/O FINISH)	88 LBS (40 KG)
CAB WEIGHT (W/O FINISH)	408 LBS (185 KG)
GROSSLOAD	1332 LBS (604 KG)

RAIL FORCE DETAIL		
R1 AT RUNNING	127 LBF / 565 N	
R2 AT RUNNING	216 LBF / 961 N	
R1 AT SAFETY APPLICATION	177 LBF / 787 N	
F IMPACT	1998 LBF / 8887 N	
R1 SEISMIC CONDITION	N/A	
R2 SEISMIC CONDITION	N/A	

DRAWING NAME:	GENERAL LAYOUT		
ELEVATOR(S) NUMBER:			
DETAILS:	GT-100RV06 750 LBS CAPACITY SAFETY SAFGT01		
PROJECT NAME:			
LOCATION:			
FROM :	TO:		
DATE:	VERIFIED BY:	SCALE:	N.T.S.
REV: 0	MAR.29.07	DATE	DESCRIPTION
REF.: Q-XXXXX	DRAWING #:	XXXXXX1.0	SHEET: 1/1

